



# 1:72 Blood Red Skies

## Supermarine Spitfire Mk.Ia & Messerschmitt Bf 109E-4

### A1500 SCALE MODEL CONSTRUCTION KIT

#### Supermarine Spitfire Mk.Ia

Designed by the legendary R. J. Mitchell, the Spitfire first flew on the 5th of March, 1936. The RAF received the first of its Spitfires in July 1938, with nine squadrons being operational when war was declared in September 1939. Seeing only limited action until the Battle of Britain in summer 1940, the Spitfire cemented its position through this conflict as the most famous fighter aircraft of all time. Through a combination of clever design, such as the elliptical wings, as well as the power of the Rolls Royce Merlin engine, the Spitfire proved to be the best fighter in the skies over England in 1940. While the Hurricane served in greater numbers, it was the elegant Spitfire that captured the imagination of the British public.

#### Specification

Maximum Speed: 365 mph (590km/h)

Wingspan: 11.23 m

Length: 9.12 m

Armament: 8 .303 Browning machine guns.

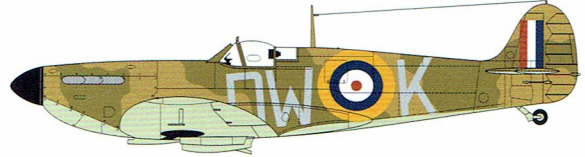

#### Messerschmitt Bf 109E-4

Designed by Professor Willy Messerschmitt, a director of the manufacturers Bayerische Flugzeugwerke AG, the prototype Bf109A first flew in 1935. The first major production variant, the Bf109E, was introduced into Luftwaffe service in December 1938. The E model was more powerful, better armed and armoured and by the summer of 1940, over 500 were in service for the offensive against Great Britain. By this time, the 109E had already proved to be a competent, if not the world's best, fighter aircraft in the skies above Poland, France and the low countries. The 109E became a symbol of the Luftwaffe over England during the Battle of Britain and along with the Supermarine Spitfire and Hawker Hurricane, it became one of the most famous fighter aircraft of all time. However, in the skies over southern England in 1940, the 109E first had its shortcomings exposed. Its range was limited, with endurance over London being just five minutes. It was also unable to turn with either the Spitfire or the Hurricane, although its cannon armament was superior. It later served on the Eastern Front, as well as over the Western Desert.

#### Specification

Maximum Speed: 354 mph (570km/h)

Wingspan: 9.85 m

Length: 8.63 m

Armament: 2 x wing mounted 20 mm MG FF cannons and 2 x nose mounted 7.9 mm MG17 machine guns.

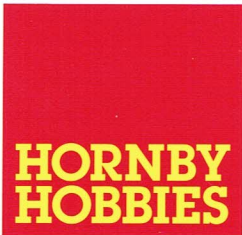
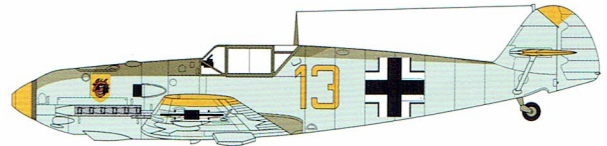

#### FOR BEST RESULTS:

Surfaces to be painted should be clean — before parts are removed from the sprue, wash in warm, soapy water, rinse and dry thoroughly. Stir paints thoroughly before use.

#### PLEASE NOTE:

Additional Humbrol paints may sometimes be required to complete models to a higher specification. Some parts in the kit may not be required to build the model specified.



Manufactured by: Hornby Hobbies Ltd Westwood, Margate, Kent, CT9 4JX, UK +44(0)1843 233525 customerservices.uk@hornby.com

EU Authorised Representative: Hornby Italia SRL Viale dei Caduti, 52/A6, Castel Mella (BS), Italy, 25030 +39 0687501292 customerservices.it@hornby.com

# ASSEMBLY INSTRUCTIONS

**EN** Study drawings and practise assembly before cementing parts together. Carefully scrape paint from cementing surfaces. All parts are numbered. Paint small parts before assembly. To apply decals cut sheet as required, dip in warm water for a few seconds, slide off backing into position shown. Use in conjunction with box artwork. Not appropriate for children under 36 months of age, due to the presence of small detachable parts.

**FR** Étudier attentivement les dessins et simuler l'assemblage avant de coller les pièces. Gratter soigneusement toute peinture sur les surfaces à coller. Toutes les pièces sont numérotées. Peindre les petites pièces avant l'assemblage. Pour coller les décalcomanies, découper le motif, le plonger quelques secondes dans de l'eau chaude puis le poser à l'endroit indiqué en décollant le support papier. Utiliser conjointement avec les illustrations sur la boîte. Ne convient pas aux enfants de moins de 36 mois - présence de petits éléments détachables.

**DE** Vor dem Zusammenkleben der Teile die Zeichnungen sorgfältig ansehen und die zu verklebenden Teile zur Vermeidung möglicher Fehler versuchsweise zusammenfügen. Dann an den Klebeflächen vorhandene Farbbeschichtung vor dem Zusammenkleben vorsichtig abkratzen. Alle Bestandteile sind mit Nummern versehen. Kleine Teile vor dem Zusammenbau bemalen. Abziehbilder wie gewünscht ausschneiden. Vor dem Anbringen einige Sekunden in warmes Wasser tauchen und dann vom Trägerpapier in ihre vorgesehene Position schieben. Dabei die Abbildungen auf der Schachtel beachten. Nicht für Kinder unter 36 Monaten geeignet, da abnehmbare bzw. lose angebrachte Kleinteile enthalten sind.

**ES** Estudiar los dibujos y practicar el montaje antes de pegar las piezas. Raspar cuidadosamente la pintura en las superficies de contacto antes de pegar las piezas. Todas las piezas están numeradas. Es conveniente pintar las piezas pequeñas antes de su montaje. Para aplicar las calcomanías, cortarlas de la hoja, sumergirlas en agua tibia durante unos segundos y deslizarlas a la posición indicada. Utilizar en conjunción con la ilustración de la caja. No es adecuado para niños menores de 36 meses, ya que contiene piezas pequeñas que podrían soltarse.

**SV** Studera bilderna noggrant och sätt ihop delarna innan du limmar ihop dem. Skrapa försiktigt bort färg från limmade delar. Alla delarna är numrerade. Måla smådelarna före ihopsättning. Sätt fast dekalerna genom att klippa arket, doppa i varmt vatten några sekunder och låta baksidan glida på plats som bilden visar. Använd enligt bildanvisningarna på kartongen. Rekommenderas ej för barn under 3 år. Innehåller lösttagbara smådelar.

**NL** Tekeningen bestuderen en delen in elkaar zetten alvorens deze te lijmen. Lak voorzichtig van lijmvlakken afschrapen. Alle delen zijn genummerd. Kleine delen vóór montage verven. Voor aanbrengen van stickers, gewenste stickers uit het vel knippen, een paar seconden in warm water dompelen en dan van het schutblad af op afgebeelde plaats schuiven. Hierbij afbeelding op doos raadplegen. Niet geschikt voor kinderen onder 3 jaar, omdat kleine deeltjes gemakkelijk kunnen losraken.

**PO** Przed przystąpieniem do sklepania przestuduj uważnie rysunki i przećwicz składanie części. Ostrożnie zeskrob ze sklepanych powierzchni farbę. Wszystkie części są ponumerowane. Drobne części pomaluj przed ich złożeniem. Celem przeniesienia kalkomanii wytnij ją z arkusza, zanurz na kilka sekund w letniej wodzie i zsuń z podłoża na wymagane miejsce. Używaj w połączeniu ze wzorami na pudełku. W związku z obecnością wielu drobnych, rozbielanych części, nieodpowiednie dla dzieci poniżej 3 lat.

**IT** Studiare i disegni ed esercitarsi a montare i vari pezzi prima di fissarli con la colla. Raschiare con cura le tracce di vernice dalle superfici da incollare. Tutti i pezzi sono numerati. Verniciare i pezzi di piccole dimensioni prima di montarli. Per applicare le decalcomanie, ritagliare il foglio nel modo richiesto, immergere in acqua calda per alcuni secondi, quindi staccare la decalcomania dalla carta di supporto e posizionarla nel punto desiderato. Usare le decalcomanie come indicato nell'illustrazione riportata sulla confezione. Non adatto a bambini di età inferiore a 36 mesi per la presenza di componenti di piccole dimensioni che potrebbero staccarsi.













**PT** Estudiar atentamente os desenhos e experimentar a montagem. Raspar cuidadosamente as superfícies de modo a eliminar pintura antes de colar. Todas as peças estão numeradas. Pintar as pequenas peças antes de colar. Para aplicar as decalcomanias, cortar as folhas e mergulhar em água morna por alguns segundos, depois deslizar e aplicar no respectivo lugar, como indicado nas ilustrações na caixa. Não convém a uma criança de menos de 36 meses devido à presença de pequenos elementos destacáveis.

**EL** Μελετήστε προσεκτικά τα σχέδια και συναρμολογήστε για πρώτη φορά τα κομμάτια χωρίς να τα συγκollήσετε. Αφαιρέστε επιμελώς την πλαστική βαφή από τις επιφάνειες τις οποίες θα συγκollήσετε. Όλα τα κομμάτια είναι αριθμημένα. Χρωματίστε τις μικρά κομμάτια πριν από τη συναρμολόγηση. Για να κολλήσετε τις χαλκομανίες, κόψτε γύρω από το σχέδιο όπως απαιτείται, βυθίστε το μερικά δευτερόλεπτα σε χλιαρό νερό και μετά τοποθετήστε το στη θέση που υποδεικνύεται, αφαιρώντας τη μεμβράνη που το καλύπτει. Λάβετε υπόψη σας ταυτόχρονα την εικονογράφηση του κουτιού. Ακατάλληλο για παιδιά ηλικίας κάτω των 36 μηνών λόγω ύπαρξης μικρών κομματιών που αποσπώνται.

**FI** Tutustu piirroksiin ja harjoittele kokoamista, ennen kuin liimaat osat yhteen. Raaputa maali varovasti pois liimattavilta pinnolta. Kaikki osat on numeroitu. Maalaa pienet osat ennen kokoamista. Siirtokuvien kiinnittämissäsi leikkaa ne arkista tarpeen mukaan. Kasta kuva lämpimään veteen muutaman sekunnin ajaksi, anna takapuolen liukua kovalle osoitettuun kohtaan. Käytetään yhdessä laatikon kuvituksen kanssa. Ei suositella alle kolmivuotiaille lapsille. Paljon irrotettavia pikkuosia.

**DA** Studér tegningerne nøje og forsøg at sætte delene sammen, inden de klæbes sammen. Skrab forsigtigt malingen af de overflader, der skal klæbes sammen. Alle dele er nummererede. Små dele skal males, før de monteres. Overførselsbillederne påføres ved at klippe dem ud af arket, som påkrævet, dyppe dem i varmt vand i nogle få sekunder, hvorefter underlaget glides af i de viste positioner. Påføres følge illustrationerne på æsken. Ikke egnet til børn under 3 år på grund af tilstedeværelse af små aftagelige dele.

# ASSEMBLY ICON INSTRUCTIONS

<p>Assembly phase Phase de montage Montagephase Fase de montaje Monteringsfasen Fase di montaggio Montagefase Fase de montagem Monteringsfase Kokoamisvaihe Faza składowania Φάση συναρμολόγησης</p> 	<p>Cement Coller Kleben Pegar Limma Incollare Lijmen Klæbes Liimaa Kleić</p> 	<p>Do not cement together No pas coller Nicht kleben No pegar Limma inte Non incollare Niet lijmen Não colar Skal ikke klæbes Älä liimaa Nie kleić Μη συγκollήσετε</p> 	<p>Symmetrical assembly Montage symétrique Symmetrischer Aufbau Montaje simétrico Symmetrisk montering Montaggio simmetrico Symmetrische montage Montagem simétrica Symmetrisk samling Symmetrinen asentaminen Montaż symetryczny Συμμετρική Συναρμολόγηση</p> 	<p>Alternative part(s) provided Autre(s) pièce(s) fournie(s) Ersatzteil(e) mitgeliefert Se incluye(n) pieza(s) alternativa(s) Alternativ(a) del(ar) ingår Uno o più componenti alternativi forniti Alternatieve onderdelen meegeleverd Peça(s) alternativa(s) fornecida(s) Alternativ(e) del(e) medfølger Vaihtoehtoiset osat pakkauskassa Dostępne części zamienne Παρέχονται εναλλακτικά κομμάτια</p> 	<p>Repeat this operation Répéter l'opération Vorgang wiederholen Repètir la operación Upprepa åtgärden Ripetere l'operazione De verrichting herhalen Repètir a operação Toista toimenpiteitä Powtórzyc operację Επανάλαβε τη διαδικασία</p> 	
<p>Decals Décalcomanies Abziehbild Calcomanías Dekaler Decalcomanie Stickers Decalcomania Billedoverføring Siirtokuvat Kalkomanie Χαλκομανίες</p> 	<p>Crystal part Pièce cristal Kristallteil Pieza de cristal Kristalldel Pezzo cristallo Kristallen onderdeel Peça de cristal Krystalstykke Kristallosa Część kryształowa Κομμάτι κρυστάλλου</p> 	<p>Weight Lester Beschweren Lastrar Belasta Applicare un peso Verzwaren Lastrar Påfor vægt Aseta vastapaino Obciążyc balastem Επιθέστε βάρος</p> 	<p>Remove by filing Enlever avec une lime Abfeilen Eliminar con lima Ta bort genom att fila Rimuovere con la lima Verwijderen door afvijlen Remove limando Fjern ved at file væk Poista villaamalla Usunąć przy użyciu pilnika Αφαιρέστε λιμόντας με λίμα</p> 	<p>Drill or pierce Percer Durchbohren Perforar Borra Trapanare o forare Boren of doorboren Furar Gennembor Poraa tai puhkaise Wywiercić lub przedziurawić Τρυπήστε</p> 	<p>Cut Découper Schneiden Cortar Skär Tagliare Snijden Cortar Skær Leikkaa Przeciąć Κόψτε</p> 	<p>Humbrol paint number No peinture Humbrol Humbrol-Farbennummer No de pintura Humbrol Humbrol färg nummer No vernice Humbrol Humbrol verfnnummer No de pintura Humbrol Humbrol malingsnummer Humbrol-maalin numero Nr farby Humbrol Νούμερο χρώματος Humbrol</p> 

1

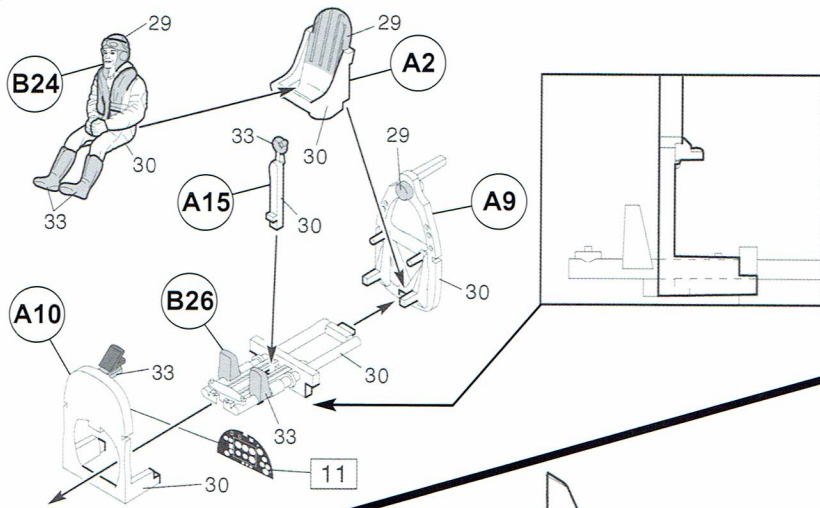

2

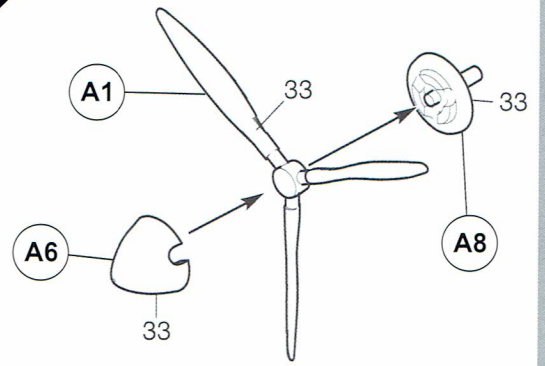

3

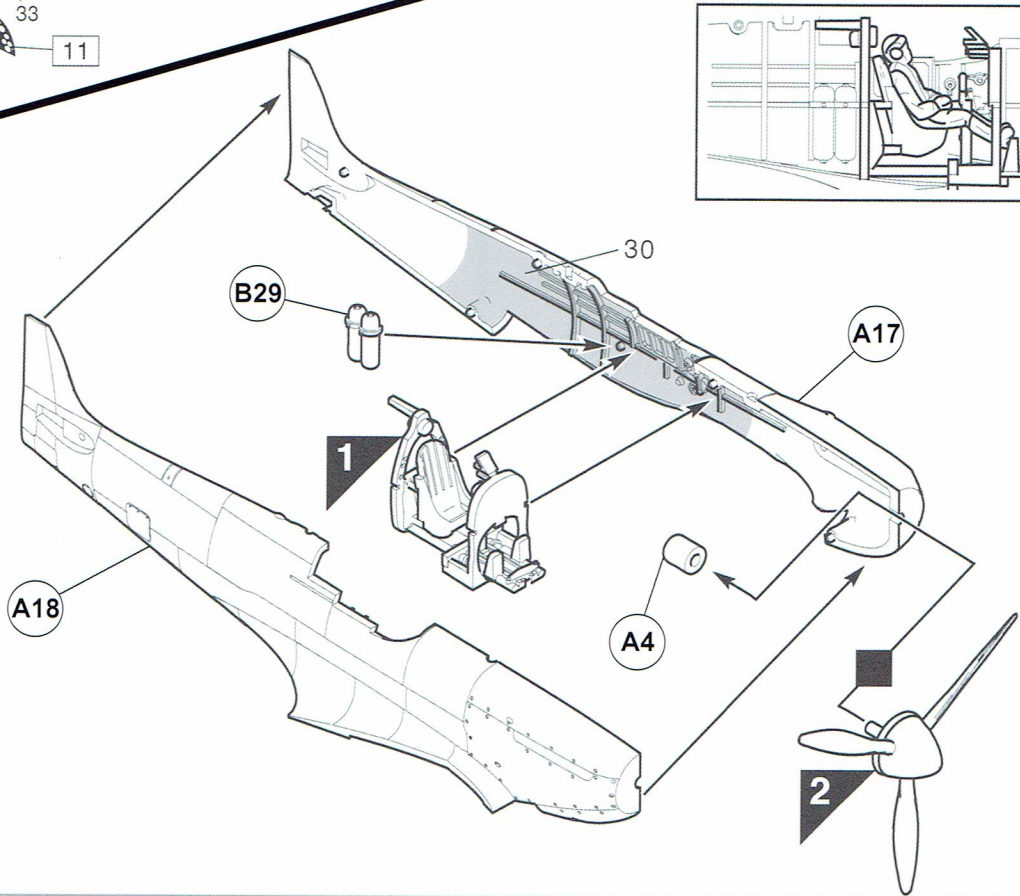

4

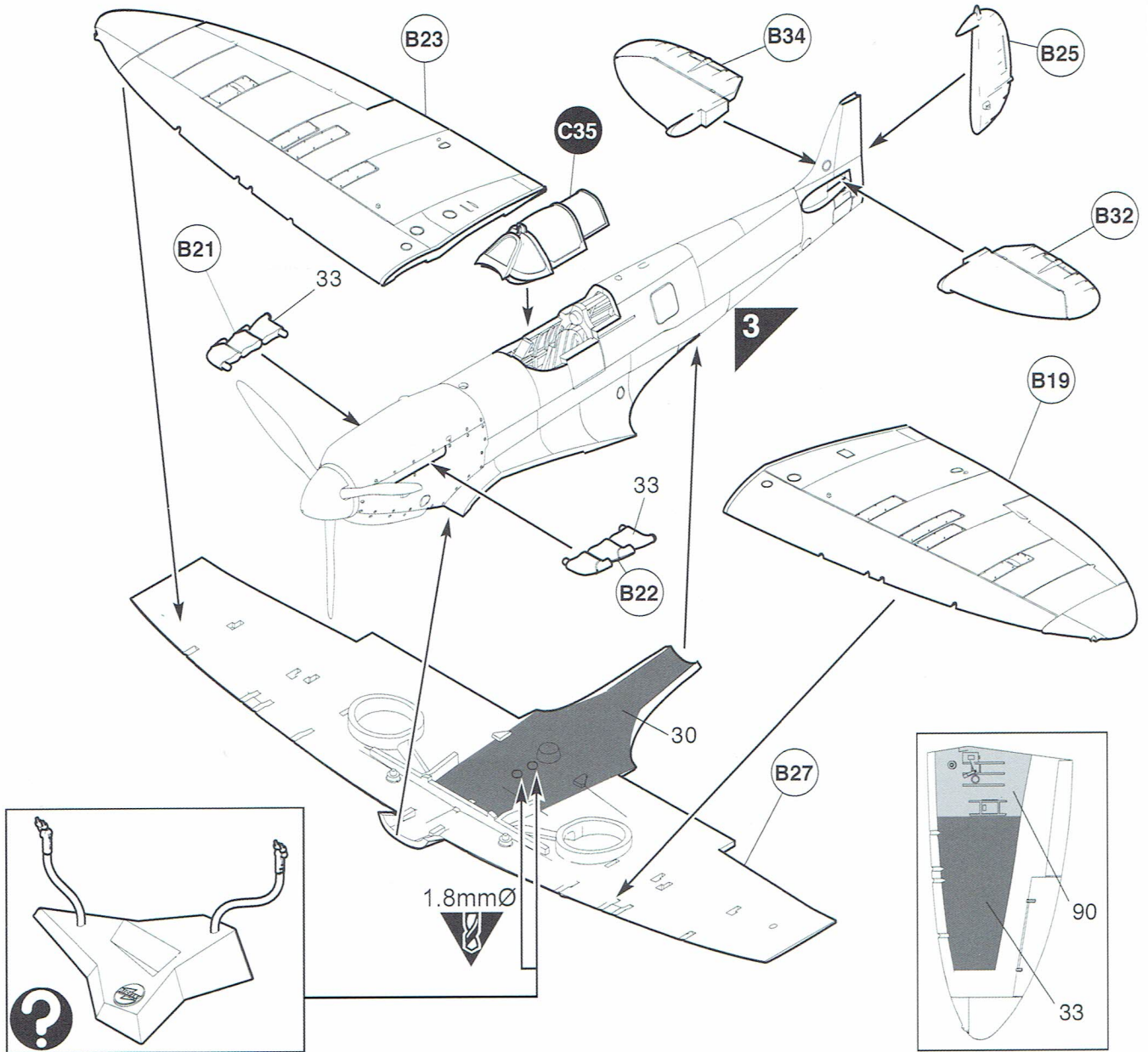

Stand available separately ([www.airfix.com](http://www.airfix.com))

5

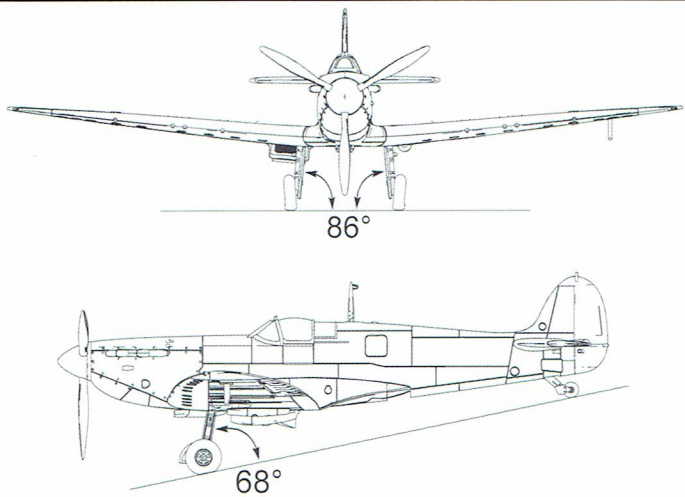
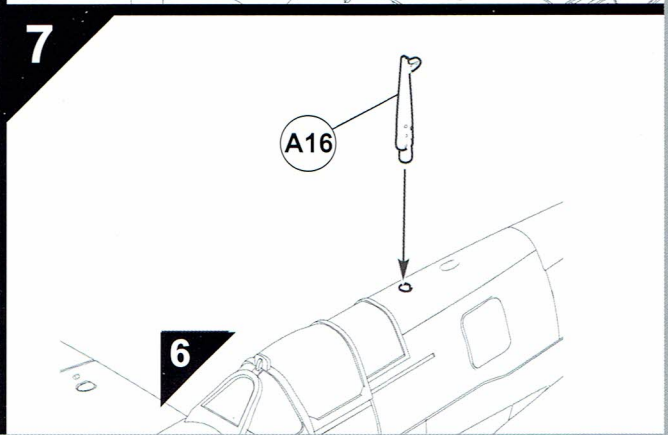
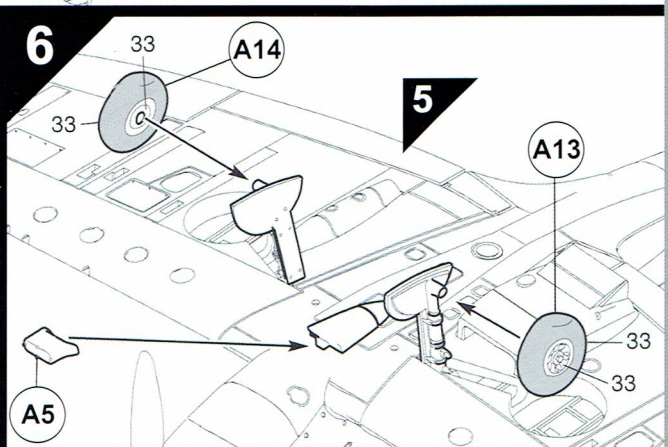
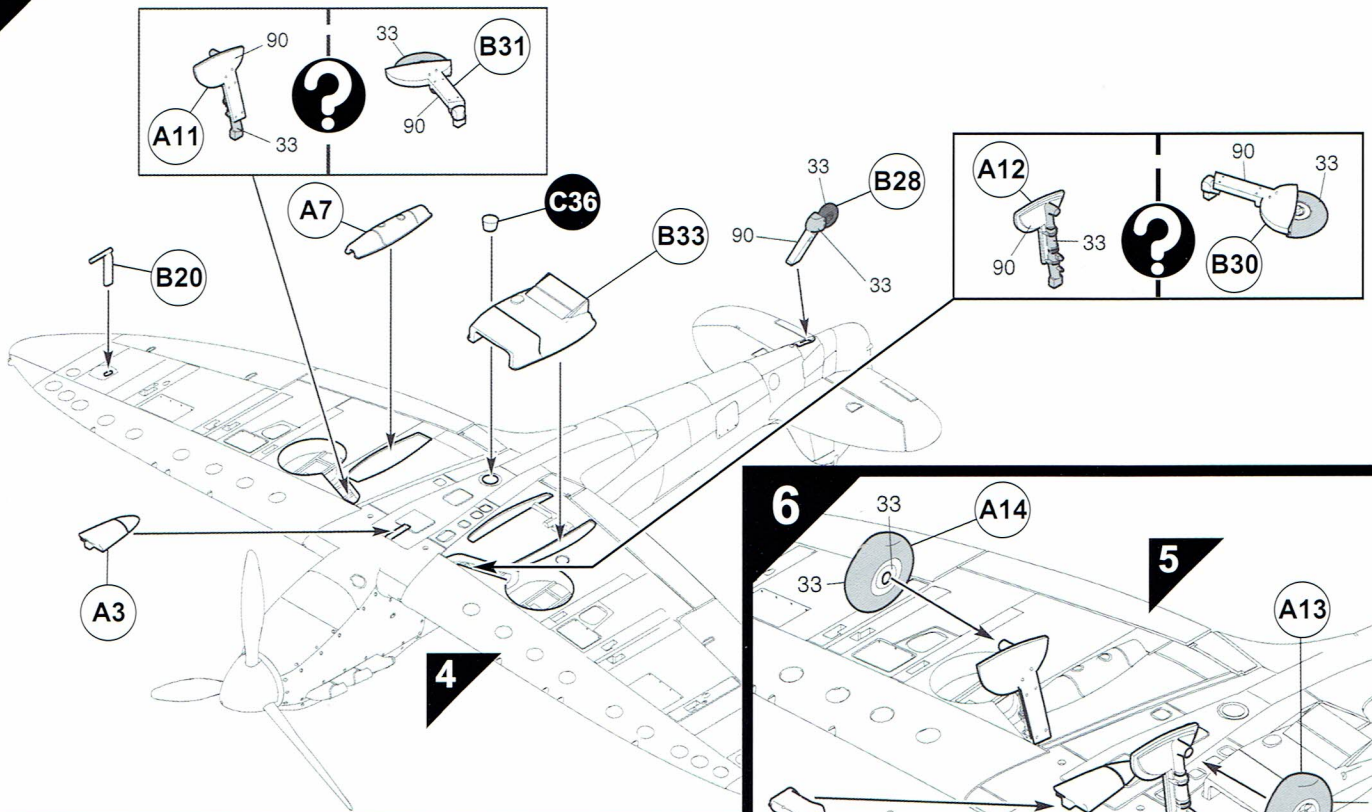

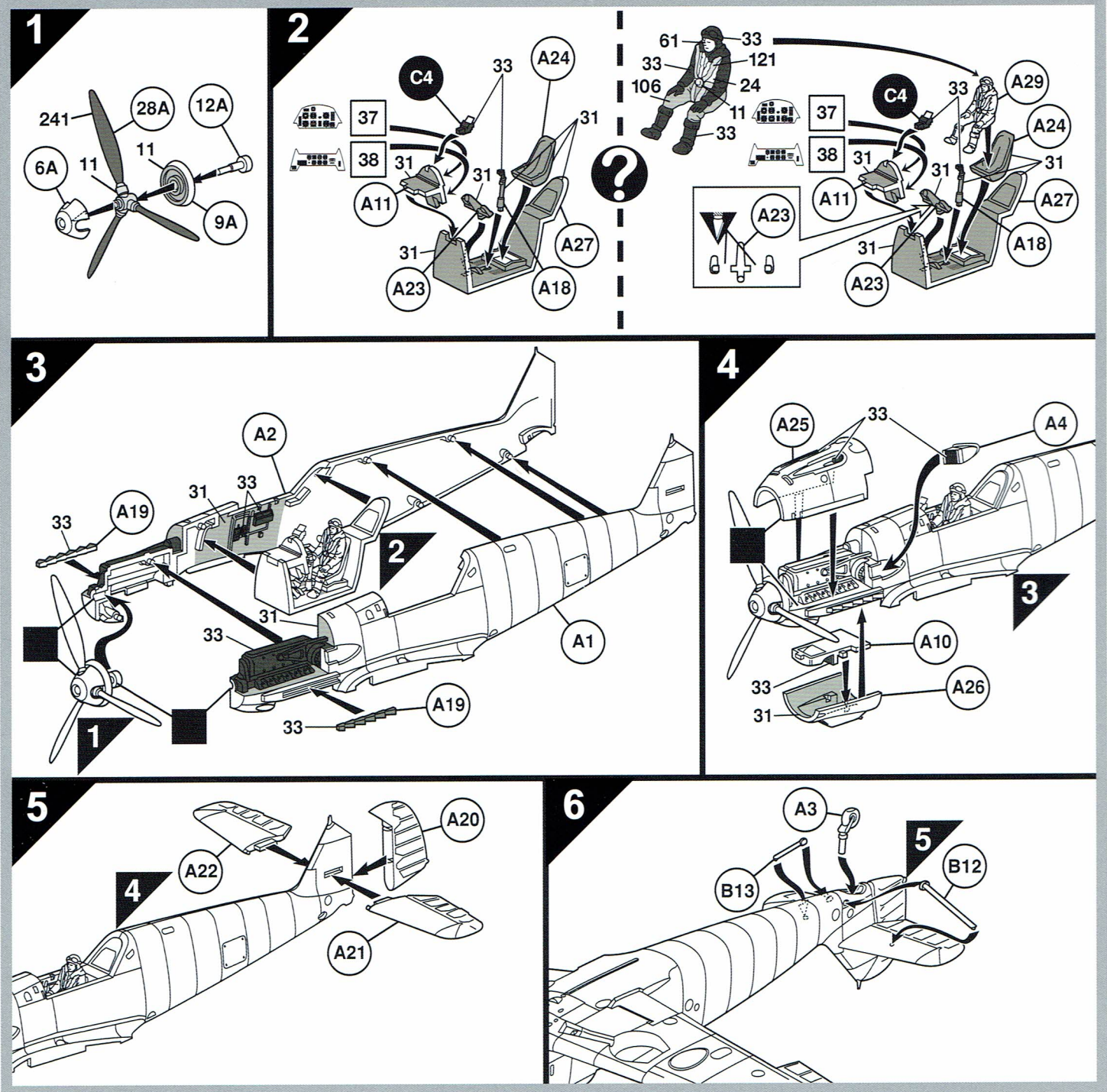

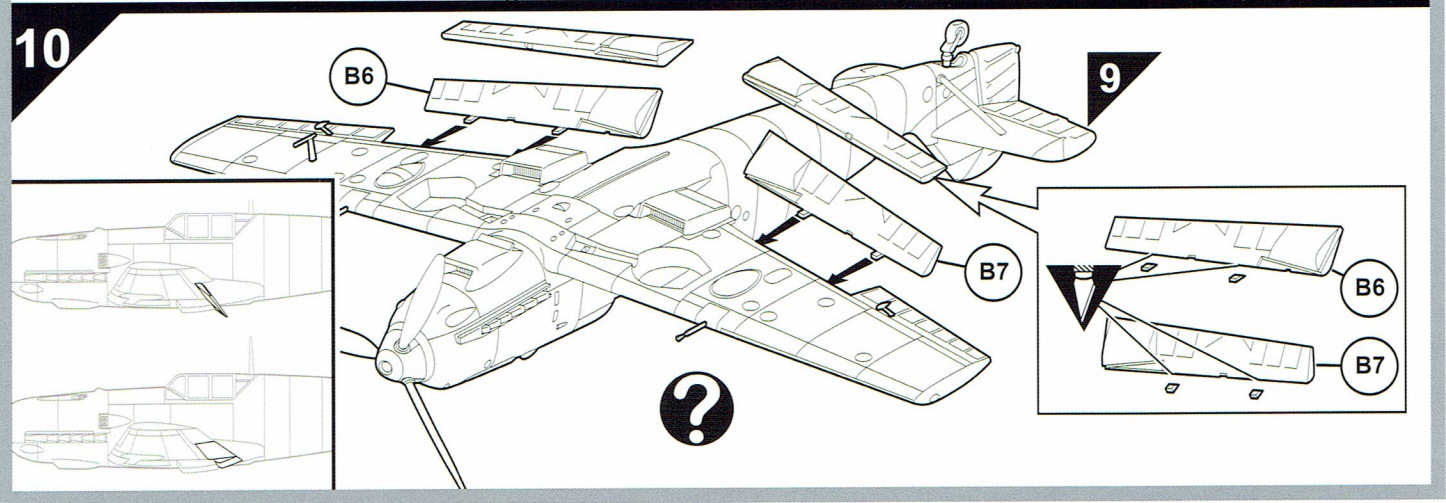
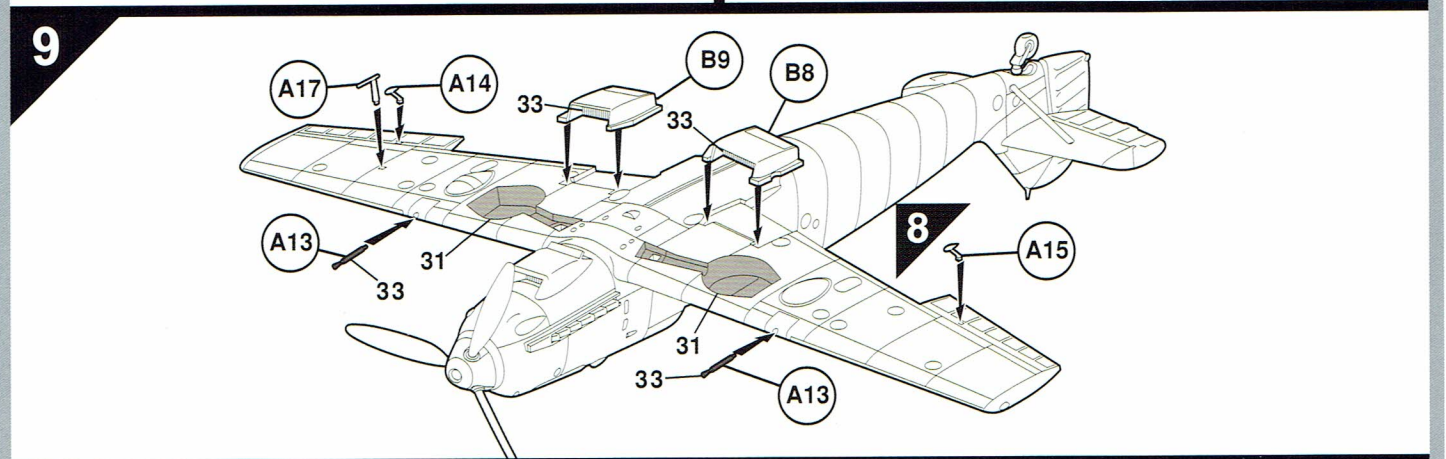
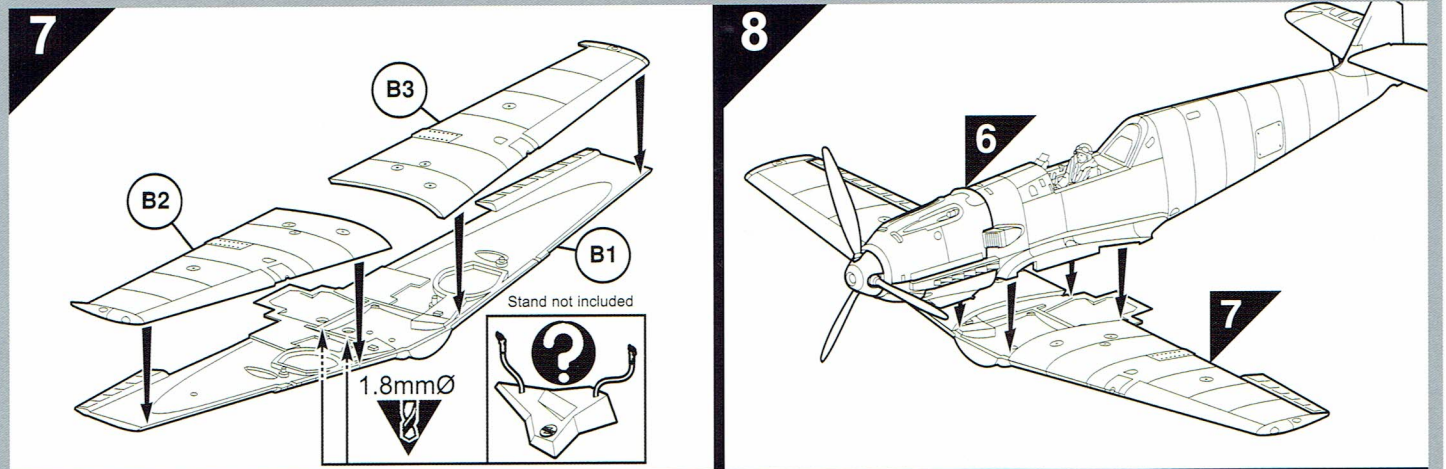

11

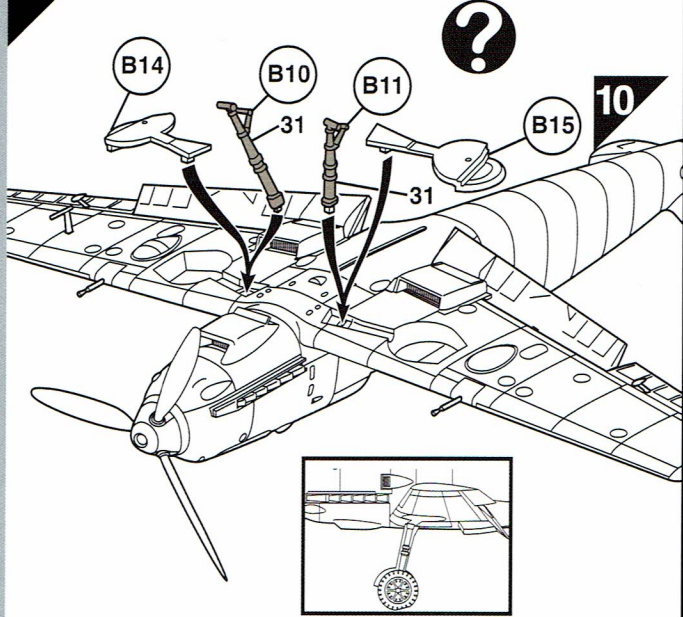

12

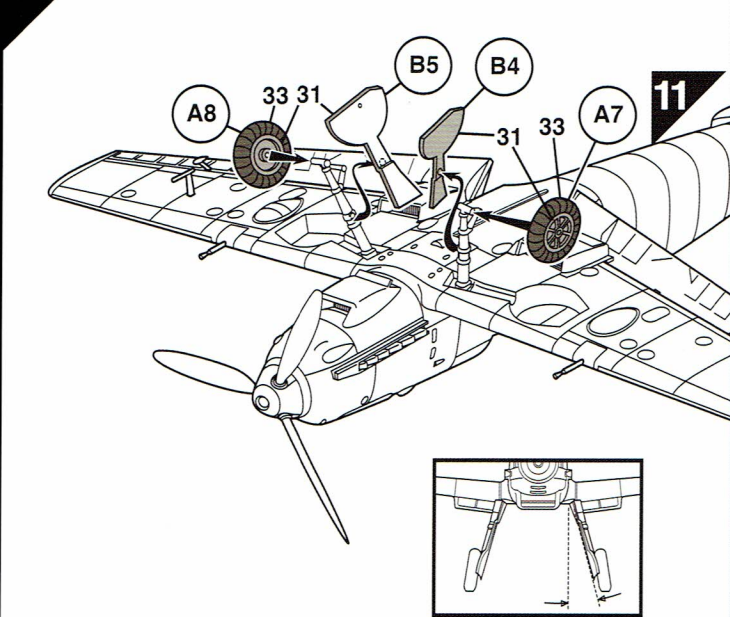

13

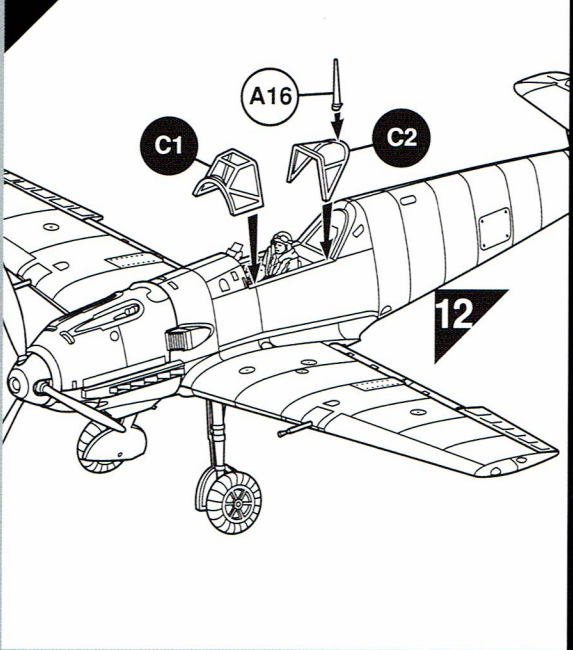

14

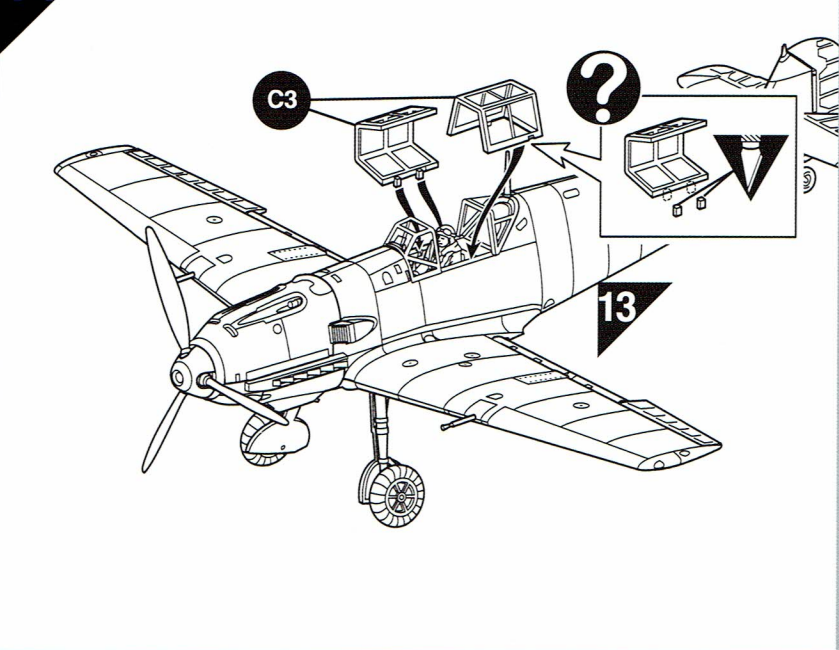

# Assembly Instructions

## BRS Extended Advantage Flying Base

To attach your new Airfix Plastic fighter planes to the BRS flying bases, you will need to use the extension base and plastic adapter supplied in the box.

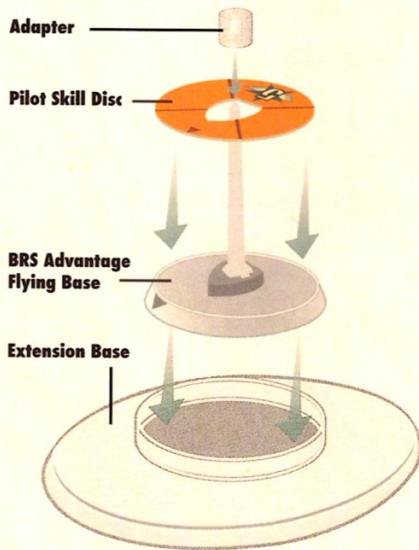

The extended base allows for the larger 1:72 scale Airfix plastic planes to stand safely on the tabletop.

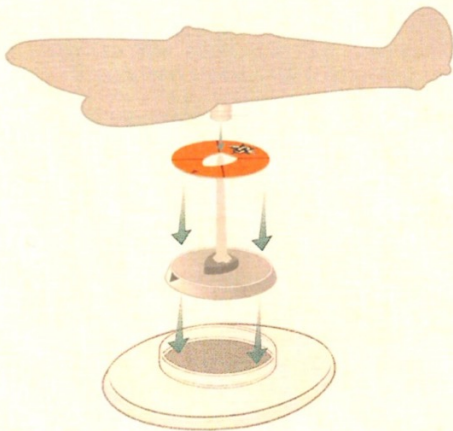

You will need to drill a small hole approximately 2mm in diameter in the underside of the plane to allow the adapter to slot securely into the plane. (drill bit not supplied)

Choose a suitable spot for the hole as shown in the example below and once you are happy with the fit, glue the adapter in place. (glue not supplied)

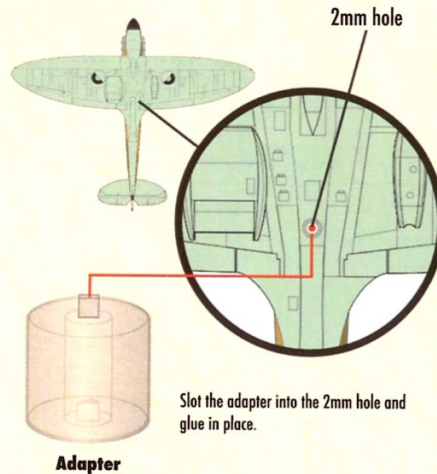

Once the adapter is fixed in place you can freely and easily attach or remove the plane from the BRS Advantage Flying Base.



## Propeller Disc

The BRS Battle of Britain box set also comes with some extra propeller discs printed with a motion blur effect. These discs can be used instead of the plastic propellers to give the effect that the plane is in flight.

The diagram below shows how to attach them. For more details on Airfix plastic plane assembly, please see the Airfix assembly leaflet included in the box set.



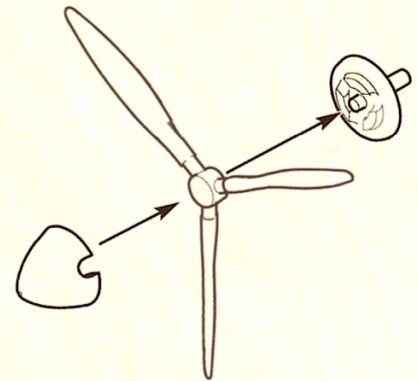

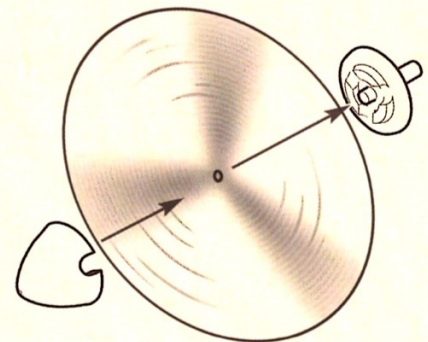

### Option A - Airfix Plastic Propeller



### Option B - Propeller Disc



Messerschmitt BF 109E-4  
 9/Jagdgeschwader 54, Holland, January 1940.

			
<b>24</b> Matt Yellow	<b>33</b> Matt Black	<b>53</b> Gun Metal	<b>65</b> Matt Aircraft Blue <small>(approx to RLM 65 Hellblau)</small>
			
<b>240</b> RLM 02 Matt Grau	<b>241</b> RLM 70 Matt Schwarzgrün	<b>242</b> RLM 71 Matt Dunkelgrün	

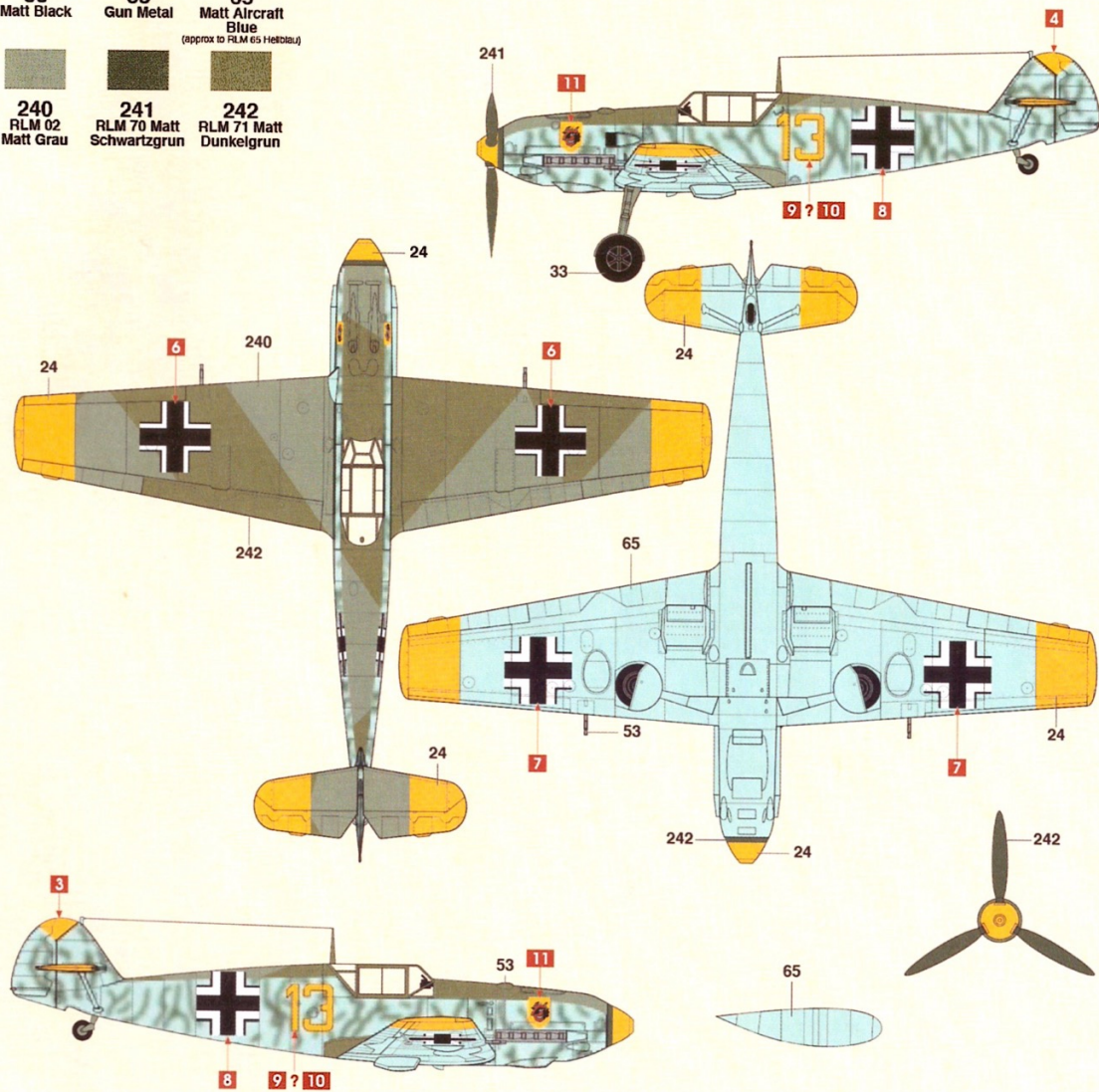

Supermarine Spitfire Mk.Ia  
 No. 610 (County of Chester) Squadron, No.13 Group, Royal Air Force Biggin  
 Hill, England, July 1940.



**24**  
 Matt Yellow



**29**  
 Dark Earth



**30**  
 Dark Green



**33**  
 Matt Black



**53**  
 Gun Metal



**90**  
 Beige Green  
 (approx. Sky)

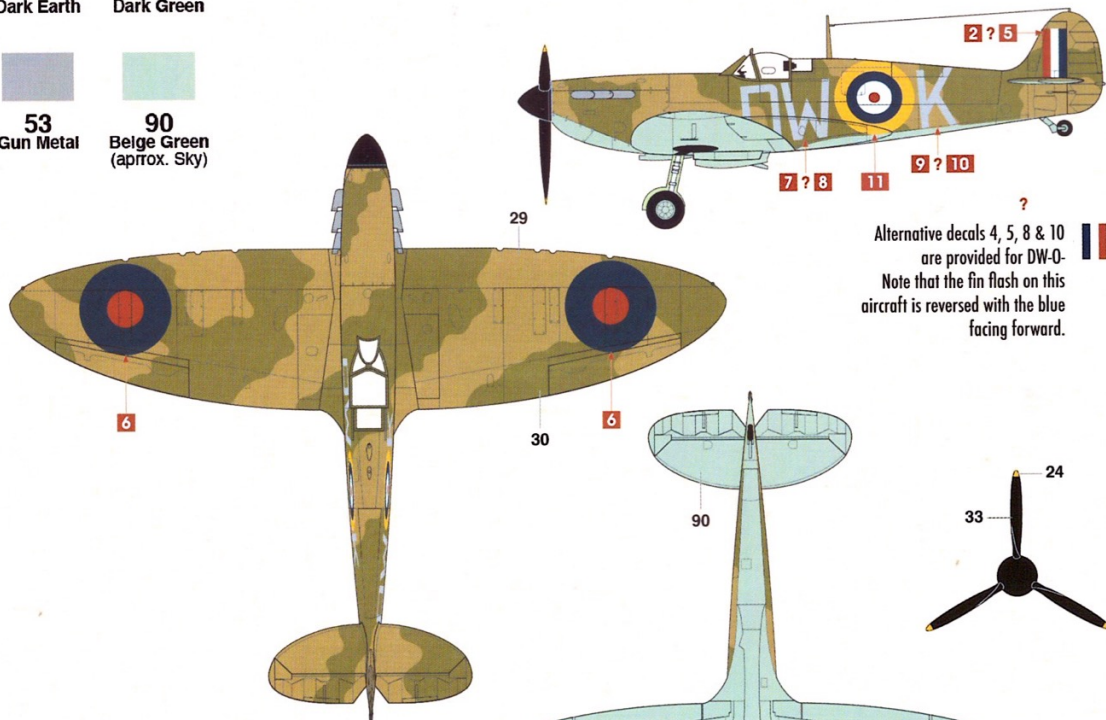

Alternative decals 4, 5, 8 & 10  
 are provided for DW-O  
 Note that the fin flash on this  
 aircraft is reversed with the blue  
 facing forward.

Alternative decals 4, 5, 8 & 10  
 are provided for DW-O  
 Note that the fin flash on this  
 aircraft is reversed with the blue  
 facing forward.

